

L(P)LGZ

系列拉袋下卸料离心机

L(P)LGZ Shaking-bag Centrifuge

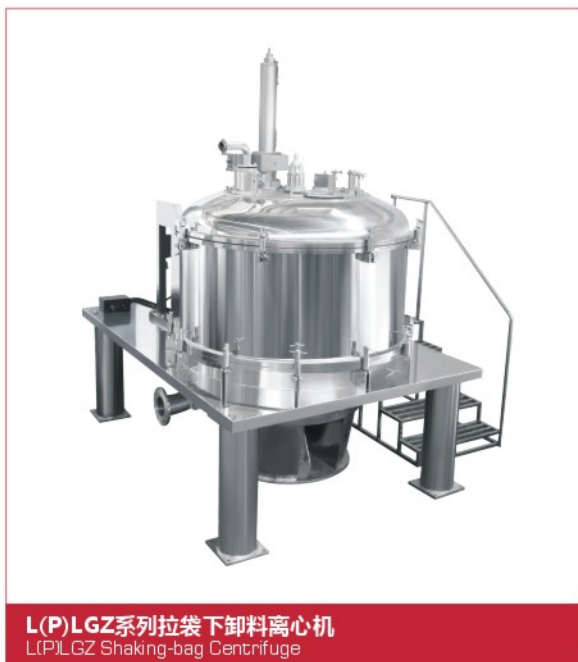

L(P)LGZ系列拉袋下卸料离心机
L(P)LGZ Shaking-bag Centrifuge

● 工作原理

卸料过程进行时, 刮刀动作, 在刮刀的作用下, 大部分物料通过转鼓底部的落料孔排至机外, 残余料层通过转鼓内部的自动拉袋机构, 产生振荡效果, 将残余料层彻底清除。

● Working principle

During the process of discharging, the scraper acts, under the impact of it most products are discharged through the blanking hole on the bottom of drum to the outside. The remnant product layer will be removed because of oscillation effect by the influence of automatic shaking-bag mechanism inside the drum.

● 主要特点

1. 变频调速, 全自动控制。
2. 具有普通立式刮刀下卸料离心机的所有优点。
3. 拉袋下降、复位全自动操作。
4. 滤布袋在转鼓内可以上下运动, 产生振荡效果, 可以彻底清除残余滤饼。
5. 可以根据需要选择大翻盖型式或者外壳全翻型式。
6. 可选配残余滤饼清除装置(获国家专利)。



● Main Characteristics

1. Automatic frequency speed control.
2. It has all advantages of common scraper centrifuge.
3. Full-automatic operation for shaking bag falling off and reset.
4. The filter bag can be moved up and down inside the drum to produce oscillation effect and remove the remnant filter cake thoroughly.
5. Big clamshell or whole shell reversible type are achievable according to users' demands.
6. The automatic residual cakes removing device is optional (have owned the national patent).

● 结构示意图 Structure Sketch Map

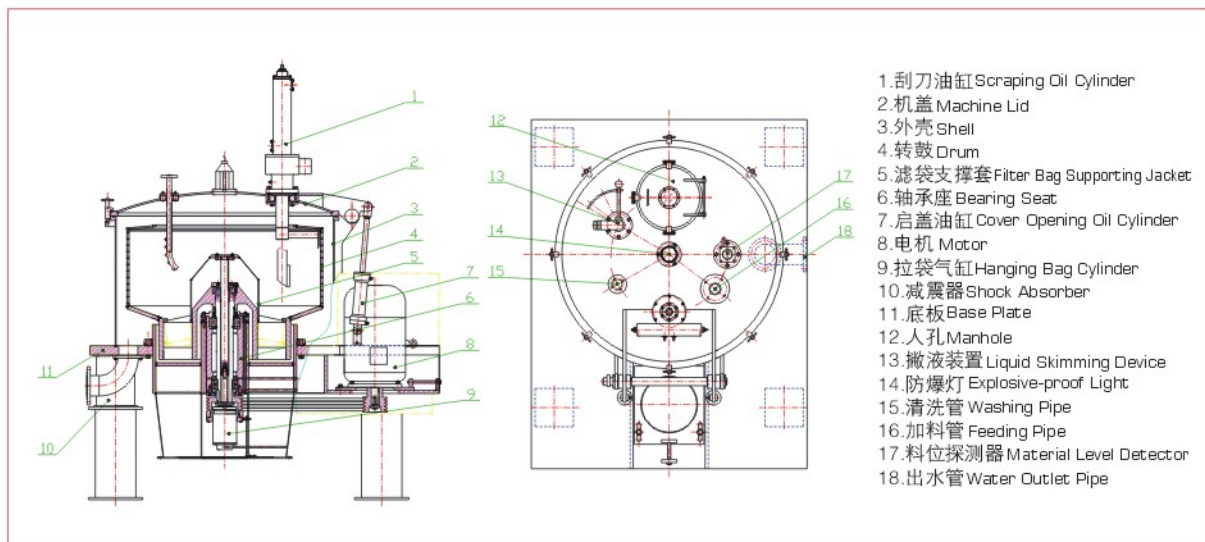

L(P)LGZ**系列拉袋下卸料离心机**

L(P)LGZ Shaking-bag Centrifuge

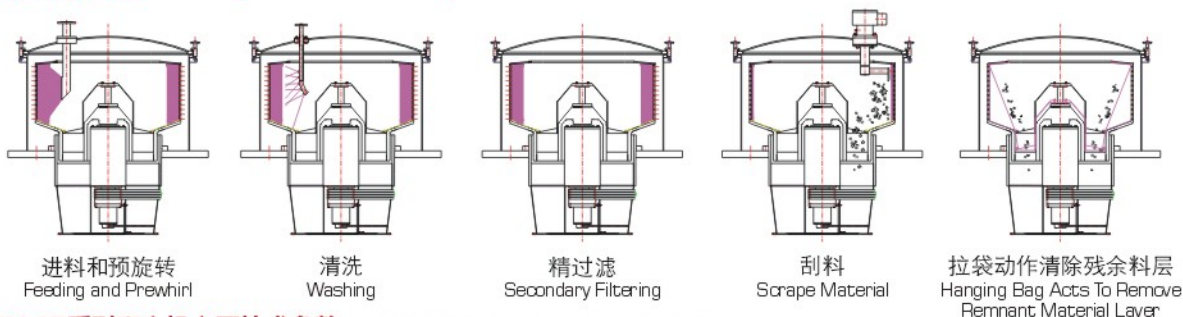
● **工作过程示意图 Working Process Sketch Map**● **L(P)LGZ系列离心机主要技术参数 L(P)LGZ Series Centrifuge Main Parameters**

项目Item	型号 Model	L(P)LGZ-800	L(P)LGZ-1000	L(P)LGZ-1250	L(P)LGZ-1600
转鼓直径 Drum diameter(mm)		800	1000	1250	1600
转鼓高度 Drum Height(mm)		400	420/580	500/630	800/720
转鼓容积 Drum volume(L)		100	110/190	310/400	800/720
装料限量 Loading capacity(Kg)		130	140/250	400/520	1000/870
最高转速 Max. Speed(r/min)		1500	1080/1200	1000/1200	850
最大分离因素 Maximum separating factor		1007	652/805	698/1006	646
电机功率 Motor power(Kw)		7.5	15	18.5/22	37
外形尺寸(含减震器) Size including shock absorber(mm)		1700x1400x2350	2100x1600x2340/2100x1600x2600	2300x1800x2400	3000x2400x3100
机器重量 Weight(Kg)		2100	3600/3900	5600	12000

随着科技的进步, 我们保留更改的权利 All right is reserved for amendment with improvement of technology

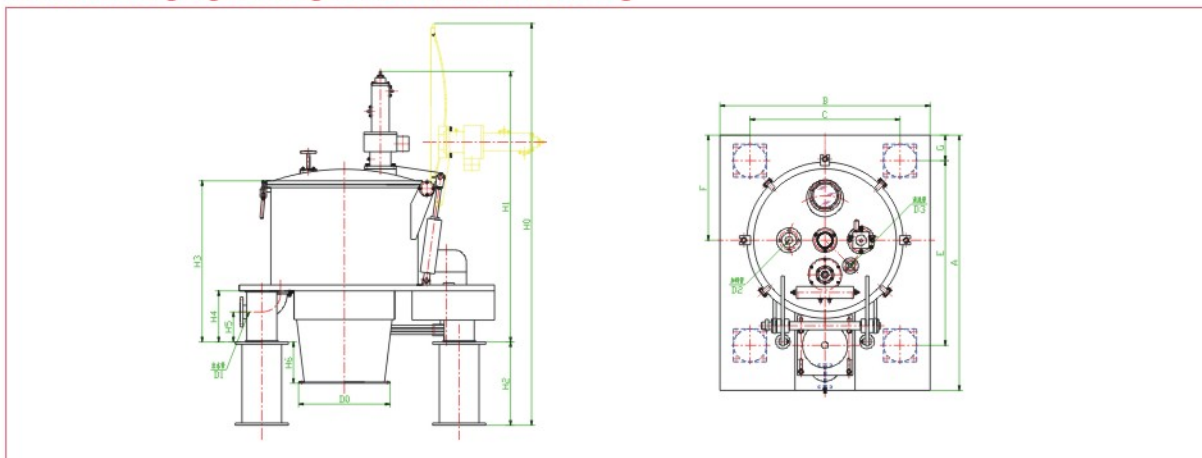
● **L(P)LGZ立式拉袋式下卸料离心机外形尺寸图
L(P)LGZ Shaking-bag Centrifuge Outline Dimensional Drawing**

型号 Model	代号 Model	A	B	C	E	F	G	H0	H1	H2	H3	H4	H5	D0	D1	D2	D3
L(P)LGZ-800		1700	1400	1000	1230	700	170	2670	1800	550	1050	320	180	φ 610	DN80	DN50	DN20
L(P)LGZ-1000		2100	1600	12100	1600	800	180	3220	2600	400	1390	340	140	φ 820	DN100	DN50	DN20
L(P)LGZ-1250		2300	1800	1500	1700	880	180	3452	2400	500	1275	340	140	φ 865	DN125	DN50	DN20
L(P)LGZ-1600		3000	2400	1900	2300	1300	250	4620	2850	710	1830	320	120	φ 1100	DN150	DN65	DN25

随着科技的进步, 我们保留更改的权利 All right is reserved for amendment with improvement of technology